

THIS DRAWING IS UNPUBLISHED. RELEASED FOR PUBLICATION
 © COPYRIGHT BY TYCO ELECTRONICS CORPORATION. ALL RIGHTS RESERVED.

LOC	DIST	REVISIONS					
		P	LTR	DESCRIPTION	DATE	DWN	APVD
G	86		A	REL PER ECR 07-019894	23AUG07	JR	MS

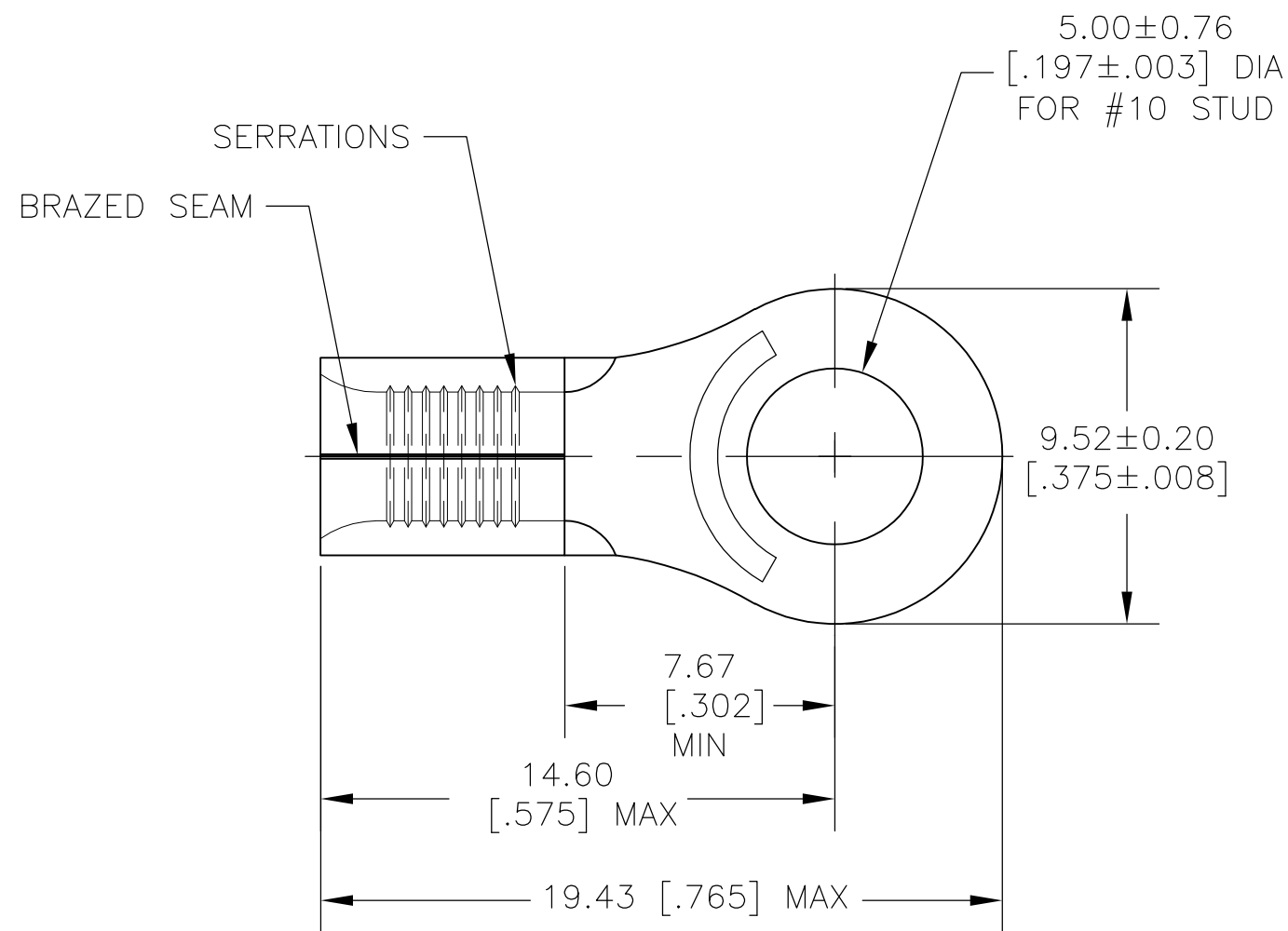

- 1 WIRE RANGE: 12-10 AWG STANDARD.
WIRE CROSS SECTIONAL AREA RANGE:
5,180-13,100 CIRCULAR MILS, STRANDED
- 2 THE TONGUE THK IS 0.99 ± 0.076 [$.039 \pm .003$]
- 3 RECOMMENDED OPERATING TEMP -55°C TO $+200^{\circ}\text{C}$ FOR HEAT SHRINK TUBING

1	1958129-1	HIGH AND LOW TEMPERTURE CROSS LINKED FLOUROPOLYMER HEAT SHRINK TUBING 6.35 [.250] MIN ID X 25.40 [1.000], RT-555
1	323062	TERMINAL BODY: COPPER PER ASTM B-152 ANNEALED FINISH: NICKEL PLATE 0.00762 [.000300] MIN THK PER SAE AMS QQ-N-290
-1	PART NO	DESCRIPTION

THIS DRAWING IS A CONTROLLED DOCUMENT.		DWN JR RUTH 06JUN07	Tyco Electronics Corporation Harrisburg, Pa 17105-3608													
DIMENSIONS: MM [INCHES]		CHK MJ SPICER 06JUN07	NAME HEAT RESISTANT TERMINAL KIT													
TOLERANCES UNLESS OTHERWISE SPECIFIED:		APVD MJ SPICER 06JUN07	PRODUCT SPEC -													
<table border="0"> <tr><td>0 PLC</td><td>± -</td></tr> <tr><td>1 PLC</td><td>± -</td></tr> <tr><td>2 PLC</td><td>± -</td></tr> <tr><td>3 PLC</td><td>± -</td></tr> <tr><td>4 PLC</td><td>± -</td></tr> <tr><td>ANGLES</td><td>± 1°</td></tr> </table>		0 PLC	± -	1 PLC	± -	2 PLC	± -	3 PLC	± -	4 PLC	± -	ANGLES	± 1°	APPLICATION SPEC -	SIZE A3	CAGE CODE 00779
0 PLC	± -															
1 PLC	± -															
2 PLC	± -															
3 PLC	± -															
4 PLC	± -															
ANGLES	± 1°															
MATERIAL -	FINISH -	WEIGHT -	DRAWING NO C-1958125	RESTRICTED TO -												
CUSTOMER DRAWING			SCALE 1:1	SHEET 1 OF 1												
			REV A													